

Product Data Sheet

TigerMag EP Magnetic Paint Flow Meter

UFS offers the Sparling Instruments TigerMag EP magnetic paint flow meter for paint flow applications. Paint will always have sufficient conductivity to measure. This device typically only requires 3 pipe diameters upstream and downstream of its installation location of straight and constant diameter pipe. The output of the meter can be used as a control input to a variable frequency drive to adjust the pump motor rpm to maintain the proper paint flow for the UF machine.

UFS offers a pre-configured kit suitable for use with E-coat paint, which combines the TigerMag EP unit and a set of grounding rings that are required for installation in a PVC pipe system. Also included in the kit is a rugged transient voltage spike suppressor that should be installed ahead of the TigerMag EP to protect its sensitive electronics.

The standard input voltage is 120/240 AC and there is an optional charge for 24 V DC input. Please see the succeeding pages for more technical information on the meters.

Pipe Size & UFS Kit Part Numbers

1-1/2"	225067
2"	225064
3"	225052
4"	225057
6"	225068
8"	225090
10"	225086
12"	225085

Larger—request specific size

Think and act in a safe manner. Always disconnect power and use a lockout before you work on the E-coat system, or any of the related subsystems. Observe any confined space conditions. Use the appropriate safety equipment and clothing for the task.

UFS Corporation . 330 North 400 East . Valparaiso, Indiana 46383 USA
+219-464-2027 . +219-464-8646 (Fax) . www.ufsc.com . info@ufsc.com

TigermagEP

Technical Specifications

FM656 Obstructionless Electromagnetic Flowmeter



DESCRIPTION

The Model 656 is a microprocessor-based electromagnetic flowmeter designed to measure the flow of conductive liquids in full pipes. The sensor and the transmitter are integral and enclosed in a NEMA-7 explosion-proof housing. The sensor housing is made of steel.

A wide variety of liners and electrodes are available to allow you to tailor the meter to your process.

The Model 656's nonvolatile EPROM memory and circuitry eliminates the need for a microprocessor backup battery. It is not necessary to reprogram if the electronic module is replaced or exchanged with electronics from another size flowmeter.

APPLICATIONS

The Model 656's high signal frequency makes it ideally suited to applications with high levels of inherent noise including: Process Chemicals, Heavy Sludges, Pulp & Paper Stock, Mining Slurries, Polymers, Acids, Alkalies, Sewage, Cooling Water. Nearly any conductive liquid can be measured.

CERTIFIED ACCURACY

Each Tigermag EP™ is wet-flow calibrated in Sparling's Primary Flow Lab traceable to the National Institute of Standards and Technology. A certificate of accuracy is furnished with each meter.

PRINCIPLE OF OPERATION

The Model 656 magnetic flowmeter is based on Faraday's Law which states that the voltage induced in a conductor moving through a magnetic field is proportional to the velocity of that conductor. The magnetic flowmeter will measure liquids with conductivities greater than 5 micromhos.

STANDARD FEATURES

- Sampling frequency up to 100 Hz for accurate measurement of fluids with high levels of inherent noise
- Forward, reverse and net totalization
- Programmable high and low flow alarms
- Nonvolatile EPROM memory
- Universal electronics module compatibility
- 2-line, 16 character backlit display
- Programming made easy with Mag-Command™
- User-selectable damping & low flow cutoff
- NEMA-4X & NEMA-7 explosion proof enclosure
- Approvals include: FM, CSA (std.)
- Rotatable modular display
- Empty pipe detection
- PZR - Positive Zero Return
- Standard 0.5% accuracy
- Sizes available from 0.5" - 72"



SPARLING

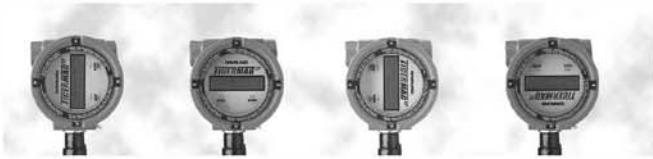

EASY TO READ BACKLIT ROTATABLE DISPLAY

The 16 character, 2-line backlit transmitter display is rotatable 360° in 90° increments ensuring easy reading in any orientation.

INSTALLATION

The meter must be mounted at a point in the line in which the pipe is always full of the process liquid under flowing conditions.

The meter may be equipped with ANSI 150 or 300 lb., AWWA, DIN, PN10 or 16, JIS 10K or 20K, or British Standard flanges.

Only three diameters of straight pipe length are required from the center of the meter to normal obstructions to obtain specified accuracies. In the smaller sizes all of the necessary straight pipe is contained within the meter itself.

E²PROM NONVOLATILE MEMORY

A backup battery is not required and there is no need to reprogram if the electronics module is replaced or exchanged. Meter identification (tube ID, serial number, K, offset, etc.) is stored on an E²PROM chip independent of transmitter electronics. The E²PROM chip has lifetime data retention.

EMPTY PIPE DETECTION - Standard

The Sparling TigermagEP™ is designed to detect absence or inadequate volume of process fluid in the pipe and will hold the output signal to 4 mA or zero. This feature does not require any hard wiring as it is a software selection. One of the most important values of this feature is that it prevents false totalization possible with other meters under partially filled pipe conditions.

EASE OF COMMUNICATIONS

The TigermagEP™ is programmable with Mag-Command or Hart Protocol. 4-20mA, RS-232 or RS-485 outputs give you flexibility when interfacing with your distributed control system.

REMOTE MOUNTED TRANSMITTER

Remote mounting of the transmitter is required when pipe vibration is excessive, when flooding is possible or where high temperature conditions exist (over 212°F / 100°C).

The TigermagEP™ remote transmitter is housed in a NEMA-4X enclosure and features a larger sized (8mm) 16 digit 2-line backlit display. All power, coil and electrode connections are made within the transmitter enclosure and junction box. The meter is programmed using Mag-Command. Hall-effect switches which are energized from outside the enclosure. The enclosure can be wall mounted. An optional bracket for pipe mounting is available.

HI-Z CIRCUITRY

The Sparling TigermagEP™ provides superior performance in liquids which tend to deposit nonconductive coatings. Hi-Z™ circuitry produces a high input impedance to the transmitter's preamplifier (10¹² ohms). The impedance of the coating is negligible as compared to the impedance of the receiving instrument. The voltage drop across the electrode coating is also negligible eliminating the need for electrode cleaners.

TWO FLOW ALARMS

Fault alarms can be configured with alarm set points between 0-99% of flow for each alarm. Open collector output turns on above programmed set point.

PZR - Positive Zero Return

An electronic circuit is activated by an external contact closure when lines go empty or when a pump or valve is shut down, indicating to the meter that it should drive the output signal to 4 mA or zero.

REMOVABLE ELECTRODES (option)

Two configurations of removable electrodes are available in sizes 6" or greater for all FM656 meters. The first configuration allows removal of the electrode after the line has been depressurized and drained. Removal is performed with an 11/32" nut driver and a 3/4" socket wrench.

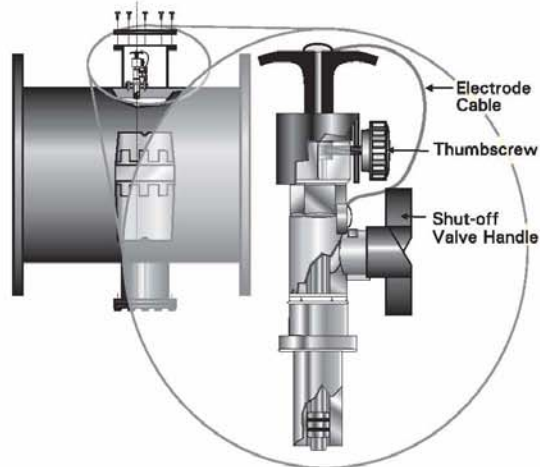

The second is the "hot-tap" electrode which allows electrode replacement while the system is still under pressure without disturbing the process flow. Removal can be easily performed with a phillips screwdriver and a crescent wrench. Special locking catches were designed to prevent high pressure accidents during electrode removal. The shut-off valve must be closed before the electrode may be removed.

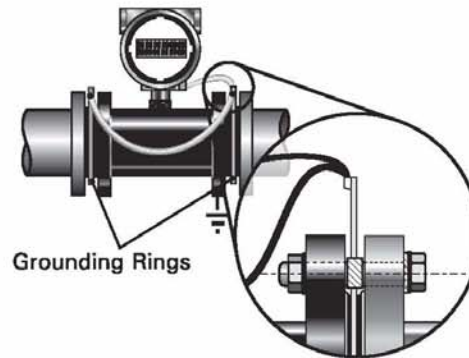

GROUNDING

The use of grounding rings is recommended to ensure accuracy. Grounding rings are required if adjacent piping is lined or nonconductive. Pump noise or excessive RF should be minimized to achieve highest accuracy.

FLOW RATES & DIMENSIONS

Table 1 - Flow & Dimensions

Meter & mating flange size (inches)	Dimensions								Flowrates - GPM - Full Scale		
	A		B		C		D		1 fps.	3 fps.	33 fps.
	150lb.	300lb.	150lb.	300lb.	150lb.	300lb.	150lb.	300lb.			
0.5	4.00	4.00	3.50	3.75	9.50	9.62	9.25	9.37	0.6	1.7	18
1	4.00	4.00	4.25	4.88	10.19	10.50	9.94	10.25	2	6	66
1.5	4.00	4.00	5.00	5.12	10.88	11.44	10.63	11.19	5	15	174
2	4.00	4.00	6.00	6.50	11.69	11.89	11.44	11.64	9	27	303
3	6.00	6.00	7.50	8.25	13.00	13.40	12.75	13.15	20	60	664
4	6.00	6.00	9.00	10.00	14.38	14.88	14.13	14.63	35	107	1182
6	13.38	14.88	11.00	12.50	17.00	17.75	16.75	17.50	85	254	2800
8	13.38	15.40	13.50	14.25	19.40	19.78	19.15	19.53	145	436	4800
10	18.15	20.55	16.00	17.50	22.56	23.31	22.31	23.06	236	709	7800
12	19.40	21.78	19.00	20.50	25.00	25.75	24.75	25.50	333	1000	11000
14	21.38	23.75	21.00	23.00	26.67	27.67	26.42	27.42	409	1227	13500
16	23.38	25.88	23.50	25.50	28.97	29.97	28.72	29.72	545	1636	18000
18	27.25	29.88	25.00	28.00	31.14	32.64	30.89	32.39	667	2000	22000
20	27.63	30.40	27.50	30.50	33.39	34.89	33.14	34.64	879	2636	29000
24	32.75	35.75	32.00	36.00	37.44	39.44	37.19	39.19	1273	3818	42000
30	43.50	46.63	38.75	43.00	43.72	45.85	43.47	45.60	1909	5727	63000
36	47.75	50.85	46.00	50.00	50.20	52.20	49.95	51.95	2925	8775	96525
42	51.75	55.12	53.00	57.00	56.90	58.90	56.65	58.65	4040	12120	133320
48	51.75	55.38	59.50	65.00	63.05	65.80	62.80	65.55	5322	15966	175626
54	53.50	*	66.25	*	69.88	*	69.63	*	7144	21433	235800
60	65.50	*	73.00	*	76.75	*	76.50	*	8500	25500	280500
66	65.50	*	80.00	*	83.75	*	83.50	*	10300	31000	341000
72	72.75	*	86.50	*	90.00	*	89.75	*	12700	38100	419100

Dimensions for flanges. Allow 1/8" to 1/4" for lining thickness / Dimensions C & D +.0125"

HOW TO ORDER A TIGERMAG EP MODEL 656

Base Model Number
FM-656 - TigermagEP

Size

OD = 0.50", OF = 1", OG = 1.5", O2 = 2", O3 = 3", O4 = 4", O6 = 6", O8 = 8", etc.

Table 3 - Liner Material

1 Hard Rubber (6"-72")	3 Tefzel® (0.5"-48")	6 Ceramic liner (0.5"-2")
2 Soft Rubber (6"-72")	5 Polyurethane (1"-48")	9 Neoprene (6"-72")

Table 4 - Electrode Material

1 316SS	4 Titanium	7 Platinum
2 Hastelloy C	5 Tantalum	8 Zirconium
3 316SS Bullet Nosed	6 Fused Platinum	9 Monel

Table 5 - Flange Rating

1 150 lb. flanges	4 PN 10 DIN	6 JIS 10K
3 300 lb. flanges	5 PN 16 DIN	7 JIS 20K

Table 6 - Transmitter and Mounting

0 Integral NEMA-4X/NEMA-7 enclosure
1 Remote NEMA-4X/NEMA-7 enclosure, 15' cable
3 Remote NEMA-4X/NEMA-7 enclosure, 15' cable, accidental submergence proof sensor
5 Remote NEMA-4X enclosure, 15' cable
6 Remote NEMA-4X encl., 15' cable, accidental submergence proof sensor
7 Remote NEMA-4X encl., 15' cable, permanent submergence proof sensor

Table 7 - Power Supply*

0 77-265 VAC Power	1 12-60 VDC Power
--------------------	-------------------

Special Notes for Construction

- ___ Hart® protocol (KP602 programmer available)
- ___ RS-485 Communications port
- ___ High temperature coils - required for temperatures over 266 °F
- ___ Requires remote mount option from Table 6
- ___ Ceramic max temp 420 °F / Tefzel® max temp 300 °F @ 100 psi
- ___ Hot Tap removable electrode design (6" & above only)
- ___ Removable electrode design (6" - 72")
- ___ Special cable length (over 15 feet - Max. 100 ft.)
- ___ Alarm with relay contacts (remote only)

Integral Mount Transmitter

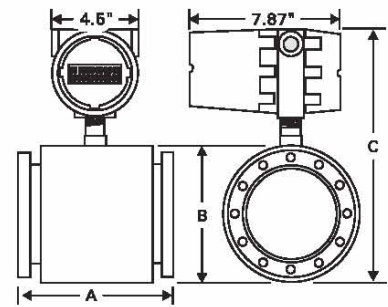

Remote Mount Transmitter

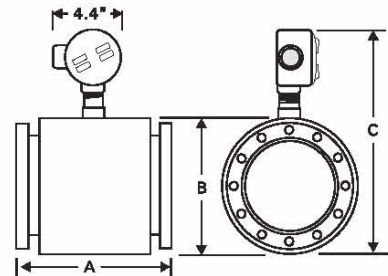

▲ Sensor

▼ Transmitter Enclosure (NEMA-4X)

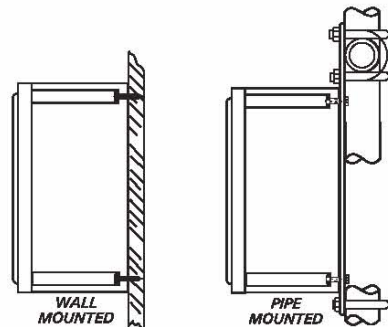
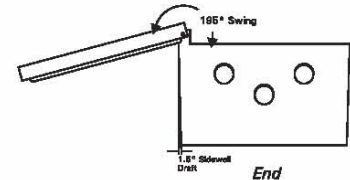
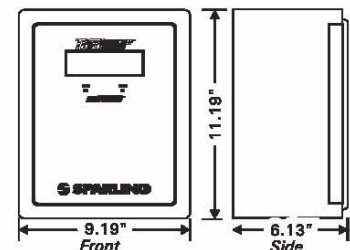

STANDARD SPECIFICATIONS

Accuracy:	1.0"-72"
(Frequency Output)	0.5% of flow rate (1-33 fps)
	0.5"
	1% of flow rate (1-33 fps)
Temperature Effect:	+0.025 % FS/°C
Full Scale Ranges:	From 0-3 to 0-33 ft./sec.
Repeatability:	+0.1% full scale
Electrodes:	Stainless steel standard (others available)
Liner:	Ceramic (aluminum oxide 99.5%), Hard Rubber, Soft Rubber, Neoprene, Polyurethane or <i>Tefzel</i> ®
Outputs:	1) Isolated analog 4-20 mAdc into 800 ohms (std); 2) scaled pulse 24 Vdc with selectable 12.5/25/50/100 ms on time, max. freq. 60 Hz; 3) 0-1000 Hz freq., for 0-100% flow rate. 15 Vdc; 4) two flow alarms; 5) fault, with open collector; 6) RS232 communication; 7) flow direction with open collector; 8) Positive Zero Return (PZR) for external relay contacts. Outputs 2 & 3 can be open collector if required.
Mag-Command™:	Selection and change of meter parameters by magnetic probe without opening the enclosure.
Display:	2-Line, 16 Digit alphanumeric backlit display (rate and total) Modular, rotatable 360° in 90° increments.
Conductivity:	Minimum 5 micromhos/cm
Minimum Velocity:	0.3 fps (0.1 mps)
Power Requirements:	*77 - 265 Vac 50/60 Hz (12-60 Vdc optional)
Power Consumption:	Less than 20 Watts
Enclosures:	Transmitter: Cast aluminum epoxy coated. Integral (NEMA-7) or remote mounted (NEMA-4X). Sensor Housing: Fabricated steel, epoxy coated.
Electrical Rating:	FM- Class I, Div. 1, Groups B, C, D; Class II, Div. 1, Groups E, F, G (150 psi integral mount), CSA Approved for Class 1, Division 2
Preamp Impedance:	10 ¹² ohms minimum.
Ambient Temp:	-20° to 140°F (-30° to 60°C) Display darkens over 158°F (70°C)
End Connections:	150 lb. or 300 lb.
Sensor Tube:	304 Stainless Steel
Process Temp:	Integral Mount: Hard rubber, Soft rubber, Neoprene, Polyurethane/Food Grade Polyurethane -40 - 180°F <i>Tefzel</i> ®/Ceramic -40 - 212°F Remote Mount (opt) <i>Tefzel</i> ® (to 300 psi), Ceramic -40 - 266°F High Temp Coils (opt) <i>Tefzel</i> ® (to 100 psi) -40 - 300°F Ceramic -40 - 420°F
Selectable Damping:	0-99 sec.
Low Flow Cutoff:	Selectable 0-9% of FS.
Options:	<ul style="list-style-type: none"> • Remote Mounted NEMA -4X Enclosure • Remote Two-Stage Batching Transmitter • Electrode Materials: Titanium, Hastelloy C, Monel, Zirconium, Tantalum, Platinum, Fused Platinum (ceramic only) • Process Temperature to 420 °F (216 °C) (ceramic only) • 12-60 Vdc operation • Digital Communications (HART Protocol) • Accidental/Permanent Submergence Proof Sensor (remote mount only) • Removable Electrodes (6"-72" only) • Hot-Tap Removable Electrodes (6"- 72" only) • RS-485 Communication • Alarm with relay contacts (remote mount only)

MODEL FM-656 SPECIFICATIONS

1.0	The magnetic flowmeter shall be microprocessor-based, and flanged. It shall indicate, totalize, and transmit flow in full pipes.
1.1	The magnetic flowmeter shall utilize DC bipolar pulsed coil excitation, operating at frequencies up to 100 Hz and automatically re-zeroing after every cycle.
1.2	The accuracy shall be at least 0.5% of flow rate over a 33:1 turndown at all flow rates above 1 fps. Accuracy shall be verified by calibration in a flow laboratory traceable to the U.S. National Institute of Standards and Technology.
1.3	The flow sensor liner shall be Ceramic, Hard Rubber, Soft Rubber, Neoprene, Polyurethane or <i>Tefzel</i> ®. The housing shall be steel.
1.4	The integrally-mounted flow sensor and transmitter shall be FM approved for Class I, Division 1 & 2, Groups B, C, D and Class II, Division 1, Groups E, F, G environments without use of air purge. CSA Approved for Class 1, Division 2.
1.5	The electronics shall be integrally or remote mounted.
1.6	When remote mounted, the flowmeter transmitter shall be furnished in a NEMA-4X enclosure box, with a larger 3/8" character, 2-line 16 digit backlit display and 15 feet of cable (standard). Batch controller option available.
1.7	The flowmeter shall be suitable for operation at temperatures from -40°F to 266°F and at pressures from full vacuum to 740 psi. Temperatures to 420°F (optional).
1.8	The flowmeter electrodes on ceramic liners shall be fused platinum and shall not require O-rings.
1.9	The meter shall incorporate HI-Z circuitry. The preamplifier input impedance shall not be less than 10 ¹² ohms. External ultrasonic electrode cleaners shall not be acceptable.
2.0	Available outputs shall be 1) Isolated analog 4-20 mAdc into 800 ohms (standard); 2) scaled pulse 24 Vdc with selectable 12.5/25/50/100 ms on time, max. freq. 60 Hz; 3) 0-1000 Hz freq., for 0-100% flow rate. 15 Vdc; 4) two flow alarms; 5) fault, with open collector; 6) RS232 communication; 7) flow direction with open collector; 8) Positive Zero Return (PZR) for external relay contacts. Outputs 2 & 3 can be open collector if required.
2.1	Low flow cutoff shall be selectable from 0-9% of FS and there shall be two flow alarms settable from 0-99% of span.
2.2	A 2-line, 16 character backlit alphanumeric display shall indicate user-defined flow units and total flow. All menu advice and commands shall be visible on this display. The display shall be modular and rotatable 360°, in 90° increments. Characters shall be at least 0.125" high for ease of readability.
2.3	The flowmeter shall incorporate the MAG-COMMAND feature allowing menu selection and changes to be made from outside the housing via Hall-effect sensors. It shall not be necessary to remove covers, panels or fasteners to accomplish calibration or program changes.
2.4	The TigermagEP's unique diagnostic functions eliminate the need for a technician to carry test equipment or open the housing. Current ramp, complete coil check and true front-end input simulator may be activated in MAG-COMMAND without opening the enclosure.
2.5	The meter software shall incorporate a password feature preventing inadvertent program changes.
2.6	The meter shall feature nonvolatile E ² PROM memory and universal electronics module compatibility between all TigermagEP meters.
2.7	The flowmeter shall have a switching power supply having an operating range from 77 - 265 Vac 50/60 Hz (12-60 Vdc). Power consumption shall not exceed 20 Watts.
2.8	All printed circuit boards shall be contained in a plug-in module and be interchangeable for any size without requiring test equipment.
2.9	The flowmeter manufacturer shall have meters of the DC pulse type in similar flowing mediums for a minimum of five years.
3.0	The flowmeter shall be warranted against defective workmanship or materials for a period of two years from date of shipment.
4.0	Totalized flow and programmed configuration shall be maintained in memory for the meters lifetime.
5.0	The flowmeter shall be MODEL 656 TigermagEP™ as manufactured by Sparling Instruments, Inc.



4097 N. Temple City Blvd. • P.O. Box 5988 • El Monte, CA USA 91731
Ph (626) 444-0571 • Fx (626) 452-0723
Internet: <http://www.sparlinginstruments.com> • E-mail: sales@sparlinginstruments.com

