

TruFlux™ Ultrafilter Systems



- Built to Outperform Others
- Accepts Any “7640 Type” UF Element
- Designed With the Operator in Mind

2012

Built to Outperform Others

System Design and Construction

UFS designs systems to produce 9.5 lpm (2.5 gpm) +/- 10% from each 7640 type 8 inch UF Element. Because we manufacture systems that provide reliable, steady long-term performance, the customer avoids the frustration of unexpected system performance after start-up. Our systems are robust — an Element can be taken off line for cleaning, replacement, or “rest” without placing stress on the remaining Elements.

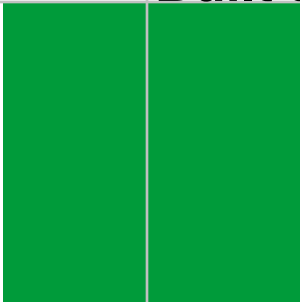

Stainless Steel Paint TruFlow Paint Manifold, note tapered diameters

TruVelocity™ Paint Manifolds

Standard Manifolds are constructed of Sch 80 PVC pipe. Optional stainless steel Manifolds are constructed of Sch 10 304 stainless steel for improved flow and long life. The diameter of the manifolds decrease along their length based on a design flow rate of ~265 lpm (70 gpm) for each 8 inch UF Element. This design provides consistent and proper paint flow velocity to all Elements and keeps paint solids in solution. The final connection is made with an elbow so there is no “dead end” where paint solids can accumulate.



PVC Paint Manifold

TruFlow™ UF Housings

The TruFlow™ UF Housing is built to deliver over the long haul. It is made of Sch 80 PVC or 304 stainless steel pipe. The inside diameter (ID) is tightly controlled to ensure a known and consistent ID, optimizing the sealing capacity of the lip seal that is part of the 7640 type UF Element. This means the PVC version has a bore at its top for about the first 20 cm (8”). At the top and bottom are durable 304 stainless steel Caps. The Top Cap includes stainless steel paint out-flow piping, which eliminates the need for PVC welds in the housing, that are prone to crack or break and cause paint leaks. Groove-type clamps connect the caps and the housings for quick and easy operation (compared to an 8 inch flange joint with 8 bolts, nuts, and washers).

Bag Filters (Optional)

Our systems include integrated bag filters (one filter for each Element), each with its own isolation valve(s). Even with our smallest 2 x 8” system, bag filters can be serviced without interrupting paint flow to any Element. While some events — like power outages — are unavoidable, our design can reduce unwanted problems that may occur when the flow of paint is stopped inside a UF Element. The use of several bag filters provides a duplex system where filtered paint is always being sent to the UF Elements. For customers wanting a stand-alone system, UFS offers a pre-engineered system using FSI brand stainless steel #2 bag filter vessels, PVC manifolds, PVC ball valves, and a powder coated mild steel frame.



Stainless Steel Manifold with Stainless Steel Valve

Clean In Place (CIP) System

While our CIP is competitively priced, UFS doesn't skimp on superior design features that make for reliable performance. A Flush and Drain valve is part of the clean return piping, allowing heavier paint solids to flow back to the ED tank and not into the CIP clean tank, thus saving paint solids. A low level switch installed inside the CIP tank will stop the pump when the tank's liquid level is below minimum tank depth to protect the pump from cavitations. The CIP's cooling system, with cooling coil, solenoid valve and temperature controller, keep the cleaning solution within the temperature range needed to protect fragile UF membrane and PVC piping. UF membranes are also protected by a filter bag vessel installed in the CIP piping that removes dirt from the cleaning solution before it flows back into the UF Elements.

Accepts Any "7640 Type" UF Elements

Tired of figuring out which vendor's element fits in your system? With a UFS-designed UF System, "customized" elements are a thing of the past! Our TruFlow UF Housing will accept any nominal diameter 7.6 inch (i.e. '7640' or equivalent with the '76' in the model designation) spiral-wound element designed for a paint feed flowrate of less than 70 gpm.

7640 type UF Elements originally were made with female permeate connections, and vendors provided bottom and top adapters to fit. Since then, in a effort to shut out competition, vendors have customized housings and elements in a confusing array of male/female configurations. **UFS's TruFlow UF Housing gives control back to the customer.** Our adapters are not attached to the housing or the element, so our system can accept male or female elements. UFS encourages the use of female UF Elements. If a seam leak develops in this type of Element top end, it can be turned over to extend its useful life.

Frame

The sturdy powder-coated frame is constructed to support the piping and UF Housings during shipment and operation at your plant.

Designed With the Operator in Mind

- Operator checklists on machine.
- Onsite training programs available. Customized programs that train on the concepts behind paint ultrafiltration, machine schematics, machine operation, maintenance and FAQ's.
- Optional Permeate Monitor System provides monitoring of permeate flow from each UF module. This system can be integrated with your PLC system to provide trend charts, alarms and reports.
- Color Coded Valve Tags.

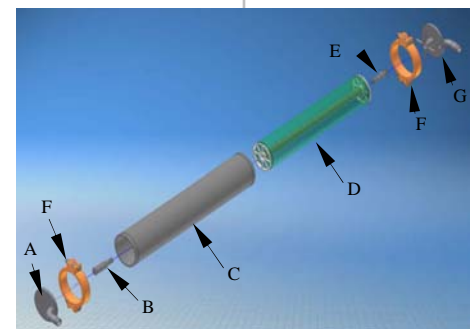

Component Description List

- A. Bottom End Cap
- B. Bottom UF Element adapter
- C. PVC UF Housing with bore
- D. Female type UF Element
- E. Permeate UF Element adapter
- F. Groove Clamps (2)
- G. Top End Cap

TruFlux UF System

1. Painted Steel Sub Frame

Holes for anchors and bolts are pre-drilled in each corner. Lifting points are provided at each corner. Frame is powder coated black and includes concrete anchors.

2. TruFlow™ UF Housings

Sch. 80 PVC (with bored portion to seat lip seal properly) or stainless steel pipe, square cut seal, and stainless steel Top and Bottom Caps, attached with a Victaulic groove-type clamp at each end.

3. Spiral UF Elements (not shown)

Any industry standard 7640 type 8 inch UF Element with a nominal diameter of 7.6 inches will fit the TruFlow UF Housing.

4. Butterfly Paint Manifold Valves

One each installed on the Paint Inlet and Outlet Manifolds to control flow in or out of the UF System. (Premium version Gear Operated Paint Valves depicted in drawing.)

5. TruVelocity™ Paint Manifolds

Sch. 80 PVC or stainless steel pipe with a tapered diameter to maintain 2.5 – 3.5 mps (8 – 12 fps) of paint velocity to ensure paint solids stay suspended.

6. Paint Isolation Valves

Two 1-½ inch PVC or SS Ball valves isolate individual TruFlow UF Housings from the paint manifolds for cleaning or replacement.

7. Clean Supply & Return Manifolds (optional, part of CIP system)

1-½ inch, PVC Sch 80 pipe transports cleaning solution to individual UF Elements.

8. Clean Isolation Valves (optional, part of CIP system)

Two 1-½ inch PVC Ball valves let cleaning solution flow through individual TruFlow Housings during the cleaning cycle.

9. Permeate Manifold

Large diameter PVC pipe, sized for low pressure drop, transports permeate to holding tank.

10. Permeate Flow Meters

One x 0 - 38 lpm (0 - 10 gpm) visual flow meter (3/4" NPT) on each UF Element's permeate outlet piping for observing permeate flow.

11. Permeate Isolation Valves

3/4 inch PVC Ball valves used to isolate the permeate flow during UF Element replacement.

12. Clean Permeate Isolation Valves and Clean Return Manifold

3/4 inch PVC Ball valve per UF Element lets cleaning solution return to CIP tank.

13. Permeate Manifold PVC Ball Valve (not shown)

Normally-open PVC Ball valve sized to the permeate manifold.

14. Permeate Purge

3/4 inch PVC Ball Valve with 0 - 38 lpm (0 - 10 gpm) flow.

15. ED Paint System Drain (optional, part of Bag Filter system)

1-½ inch valve to drain ED paint from the piping and UF Housings back to the ED bath.

16. Paint/Permeate Pressure Gauges

2 x 10 cm (4 inch) diameter gauges for paint, 1 x 6 cm (2-1/2 inch) diameter for the CIP system. Pressure gauges are protected by gauge guards and have dual (psi & bar) scales.

17. Last UF Connection is an Elbow (not shown)

There is no place for paint solids to hide or become trapped and create sludge or dirt. The last connection is an Elbow so all the paint is directed out of the paint manifolds and into the UF Elements.

18. Air Purge Valve

¼ inch valve releases air from the upper ED paint manifold.

19. Color Coded Valve Tags (not shown)

Each valve has a color coded tag: Green is for "Normally Open" valves; Red for "Normally Closed" valves; and White is for "Throttled" valves.

General Requirements

- UF paint feed pump capable of providing 16 to 19 m³/hr (70 to 85 gpm) per UF Element at 3.5 bar (50 psi) minimum, measured at the inlet manifold for each 7640 type UF Element.
- Permeate storage tank, paint line drains, DI water or RO water source.
- Platform above the rim of the ED tank is preferred location to drain paint back to bath.
- Paint line siphon breaker at highest point.

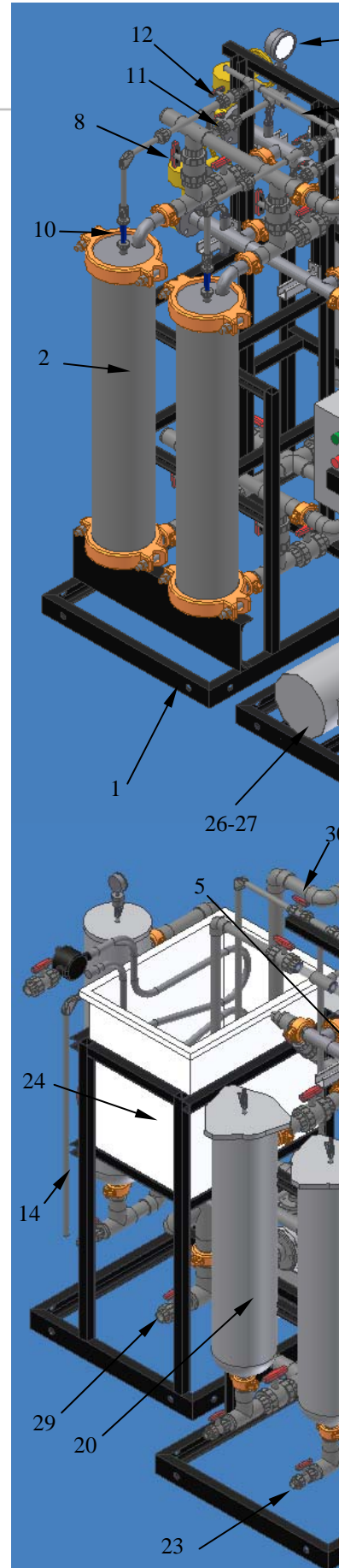

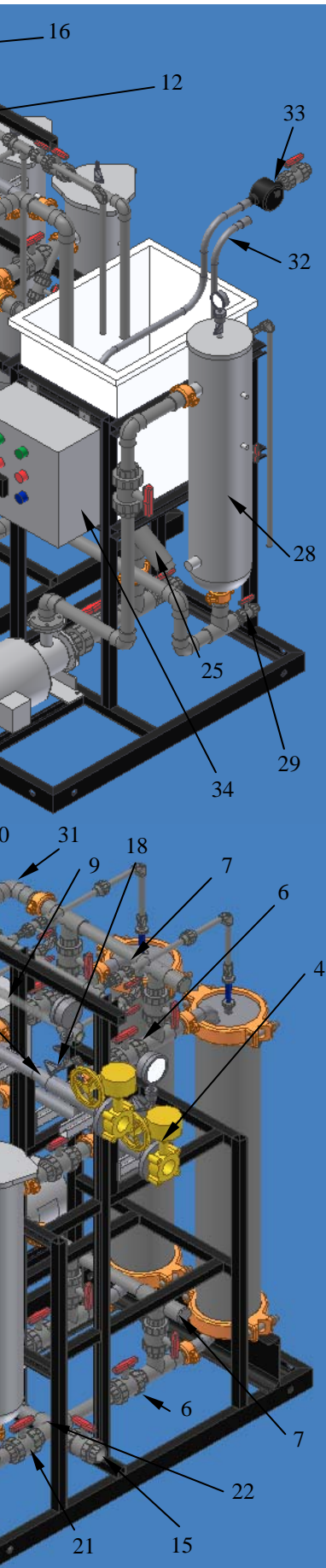

Filter Bag Vessel

ED paint must be pre-filtered before it enters the spiral UF module to remove large particles that can foul the UF Elements. Each UF Element has a dedicated filter bag vessel. Use 25 micron welded seam, glazed filter bags. Maximum allowable paint flow is 400 lpm (105 gpm) per #2 bag to avoid filter bag failure. Always check with your paint supplier for their recommendation.

20. Heavy Duty 304 Stainless Steel Swing-Bolt type Filter Bag Vessels

100 PSIG with Viton seals and 304 SS perforated support basket accepts one #2 glazed filter bag.

21. Paint Isolation Valves

Allows each filter bag to be changed individually without stopping paint flow to UF Elements.

22. PVC Balancing Manifold

Provides paint to all UF Housings, even if one vessel is offline for filter bag replacement.

23. Drain

½ inch Ball valve for each vessel to drain back to ED bath.

Clean In Place (CIP) System

Regular permeate flushing of UF Elements extends their service life and postponed the need & added expense of a chemical cleaning. A Clean-In-Place system allows the operator to isolate, flush and rinse individual UF Elements without shutting down the system.

24. Clean Tank

170 l (45 gal) polypropylene tank with lid (lid not shown) with 1 inch overflow NPT tank adapter.

25. Pump Inlet Strainer

2 inch Y strainer in the CIP pump's suction piping traps foreign objects from being ingested by the pump.

26. Circulation Pump

Single, mechanical seal, 304 stainless steel pump. 15.9 cm/hr @ 4.8 bar (70 gpm @ 70 psi) capable of flushing one UF Element at a time.

27. Pump Motor

5 HP, 220/460 VAC, 3 phase, 50/60 Hz TEFC motor.

28. Filter Bag Vessel

Bag filter installed on CIP removes dirt from cleaning solution before it flows to the UF modules. Has swing bolt type lid with Viton seals.

29. CIP Drain

1 inch drain valve on pump and a ¾ inch valve on filter vessel can drain cleaning solution/paint to ED bath or waste.

30. Permeate Fill Valve

Can be used to fill CIP tank in preparation for UF Element cleaning.

31. Flush & Drain

¾ inch valve installed in clean return line can send rinse solution that is heavy with paint solids back to the ED tank while CIP tank is being refilled with more permeate or RO water.

32. Cooling Coil

1 inch stainless steel serpentine coil cools cleaning solution, increasing cleaning cycle time by as much as one additional hour.

33. Cooling Water Solenoid Valve

1 inch 110 VAC 50/60 Hz (220 VAC 50/60 Hz is optional) solenoid valve sends chilled water through the cooling coil.

34. IP 65 & UL 508A Control Panel

Control panel front has: "panel power on" lamp; pump start & stop push switches; "cooling water on" lamp; "high temperature on" lamp; and locking hasp. Inside the controls are 110 VAC and include: motor starter/overload relay; dual set point temperature controller; 110 VAC transformer; accepts in-coming line power of 220/460 VAC (specify voltage), 3 phase, 50/60 Hz

35. Low Level Switch (not shown)

Installed in CIP tank to stop CIP pump when tank's liquid level is below minimum tank depth.

UFS's best practices include: maintain proper paint flow to each UF Element; maintain 1 bar (15 psi) outlet paint manifold pressure; and monthly permeate flush of each UF Element.

Single Sided TruFlux UF Machine



Number of 8" Modules	Permeate Rate (gpm) per 8" Module			A (Inches)	B (Inches)	L (Inches)	Weight (Dry/Wet in lbs) Single Sided
	-10%	STD	10%				
	2.25	2.5	2.75				
2	4.50	5.00	5.50	2	1 1/2	32	500/600
3	6.75	7.50	8.25	2 1/2	2	48	750/900
4	9.00	10.00	11.00	3	2	64	1000/1200
5	11.25	12.50	13.75	4	2	80	1250/1500
6	13.50	15.00	16.50	4	2	96	1500/1800
7	15.75	17.50	19.25	4	2	112	1750/2100
8	18.00	20.00	22.00	6	2	128	2000/2400
9	20.25	22.50	24.75	6	2	144	2250/2700
10	22.50	25.00	27.50	6	2	160	2500/3000

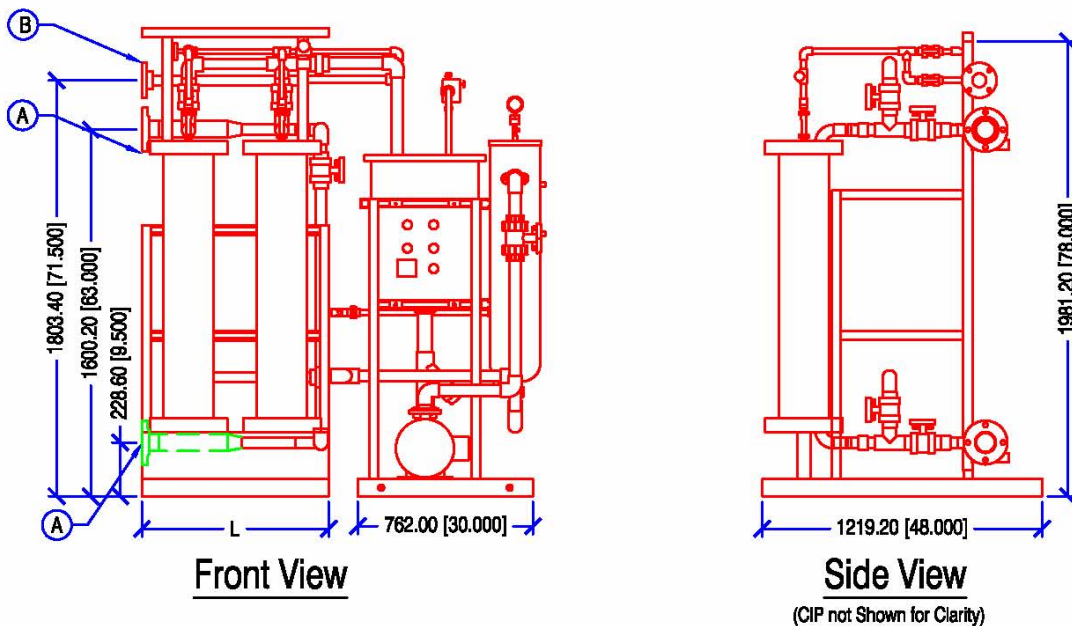

Single Sided TruFlux UF Machine

Please Note: Some piping has been removed in some views for clarity. Drawing accuracy is +/- 12.70 (0.500). Some dimensions may change during construction and final design phase.

Double Sided TruFlux UF Machine

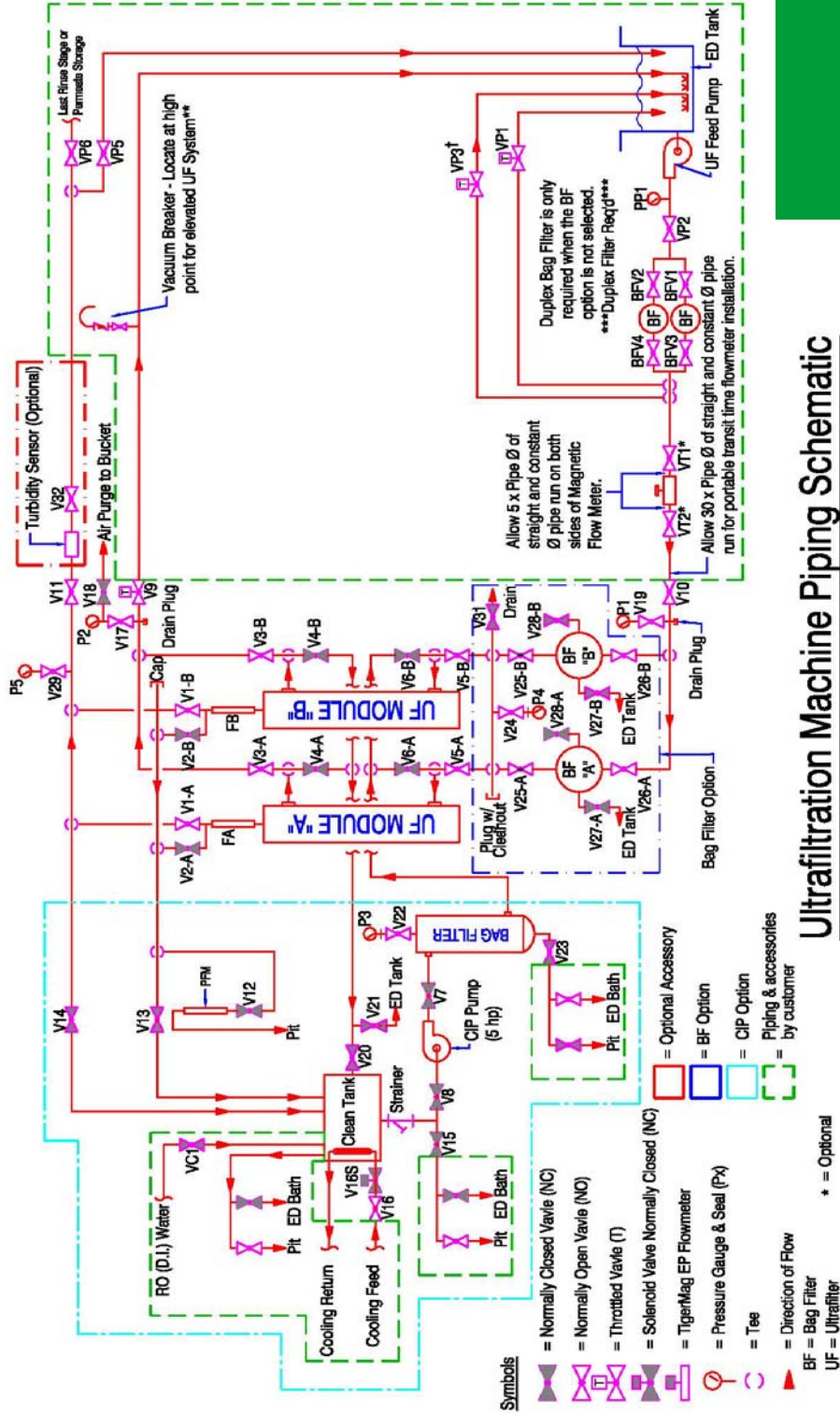

Ultrafiltration Machine Piping Schematic

Options

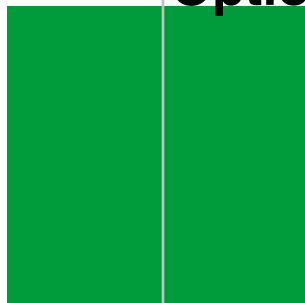

- **TigerMag EP Magnetic FlowMeter.** Proper knowledge of actual ED paint flow is important in troubleshooting UF performance. An electromagnetic flow meter installed in-line before the UF System will provide consistent day-to-day readings of paint flow through the Elements. UFS promotes the use of the TigerMag EP Flowmeter in accordance with paint company recommendations.

- **PLC based Permeate Monitoring System.** Data acquisition and trendline monitoring can be automated with this option. Included is an electronic flow meter for each UF Element, and turbidity, conductivity, and temperature sensors installed in-line.

- **Process Instrumentation.** Digital Pressure Sensor, Analog Temperature Gauge, Total Permeate Flowmeter with PVC block, Bypass Valves and Piping, and other process gauges are installed on the UF System as options when requested.

- **Drip Pans.** Sectional 302 stainless steel pans are sized to fit the bottom frame of the UF and the CIP system to collect spilled paint & permeate. These are meant to be removable so they can be cleaned from time to time.

- **Total System Cleaning.** This option is available for larger, double-sided UF systems. Used in place of the CIP system, this System will clean all the Elements at once. It requires that the UF System be taken off-line. Equipment needs include a large pump and large holding tank.

- **Permeate Holding Tank.** Stores permeate for use in rinse stages of E-coat system.

- **Turbidity Sensor.** May be used to inform the operator if the permeate is contaminated with paint solids.

- **All Stainless Steel.** If needs include an all stainless steel UF machine, UFS can provide this option.



Magnetic flow meter
for paint



Permeate electronic
flow meter



Stainless Steel
Ball Valve

UFS Corporation
330 North 400 East
Valparaiso, Indiana 46383 USA
Tel +219-464-2027
Fax +219-464-8646
www.ufsc.com
info@ufsc.com