

MEMBRANE ELECTRODE PRODUCTS For E-coat Paint Systems

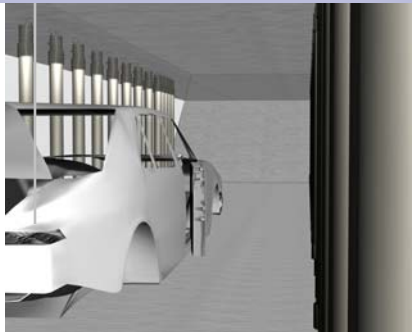

35 years of E-Coat Excellence:

- Knowledgeable Staff
- Innovative Engineering
- Well-Made, Durable Products
- Diverse Product Line

2012

Diverse Product Line

Industry Pioneers

UFS Corporation introduced the first tubular type TECTRON Membrane Electrode (ME) Cell to the United States market in 1985. Its two-part construction, with a removable anode inserted inside a Membrane Shell, is lightweight, easily-inspected and maintained; and is adaptable to fit anywhere in the E-coat tank.

Each TECTRON ME Cell is custom-manufactured to our customer's specifications, allowing material and configuration choices appropriate for each individual E-coat system. Membrane type, anode material, diameter, mounting system, top-of-cell configuration are examples of customizations we have done for our customers. We are always willing to work with our customers to engineer and manufacture new approaches to particular system needs.

Designed to Perform

The cylindrical geometry of the TECTRON ME Cell is key to the long life experienced by most of our customers. As the cross-section drawings on the opposite page depict, the membrane circumference is greater than the anode circumference. The size difference results in more ion-exchange membrane area for electrical current to pass through, for which the outcome is lower membrane current density and longer life. The ratios are below:

Membrane Area to Anode Area Ratios

Cell Size	Membrane Area to Anode Area
1-1/2"	1.42 : 1
2"	1.29 : 1
3"	1.26 : 1
5"	1.20 : 1

Roof and Floor ME Cells

Roof and Floor Cells are available in 1-1/2" and 2" diameters and can be installed on the top and bottom of the tank, respectively, to supplement side cells. In some cases (especially with densely loaded ware arrangements), roof and floor locations can be used to increase the uniformity of the ED film thickness distribution and reduce variations.

Small Diameter Cells

UFS's small diameter group of Tubular ME Cells (1-1/2" and 2") has the greatest membrane-to-anode ratio and provides the longest possible operational lifetimes. Small diameter ME Cells have the most diversified anode material offering. They are appropriate for job shops and general industrial applications, especially indexing or hoist type E-coat paint systems.

Closed Top Cells

For vertical, or indexing conveyor systems, UFS offers several designs of Low Profile Bulkheads to reduce the necessary working height of the ME Cell to a minimum. Also known as pressurized cells, they are offered in two primary styles include a compression type fitting and a NPT thread connection.

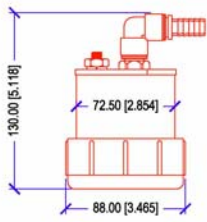
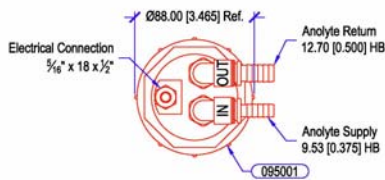

- = anolyte
- = membrane
- = paint

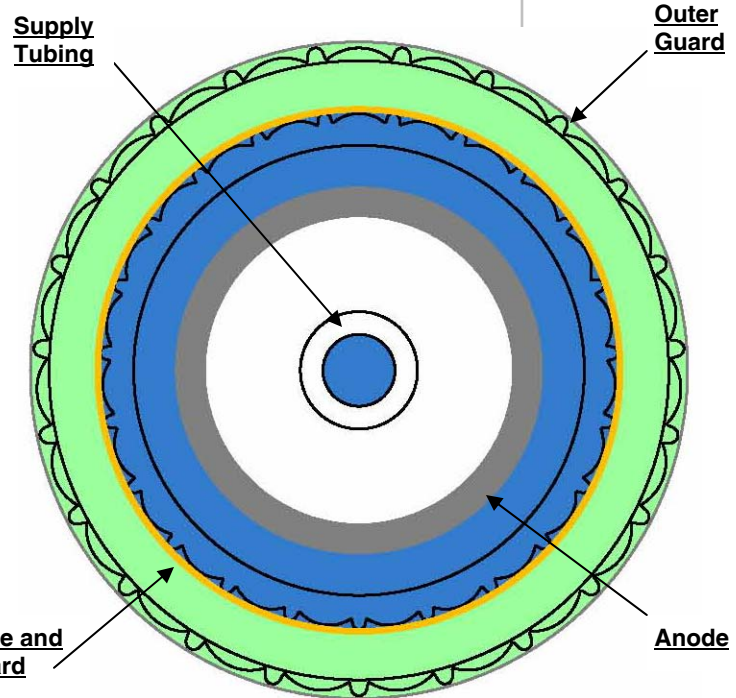

1-1/2"
TECTRON T1 Anode Cross Section

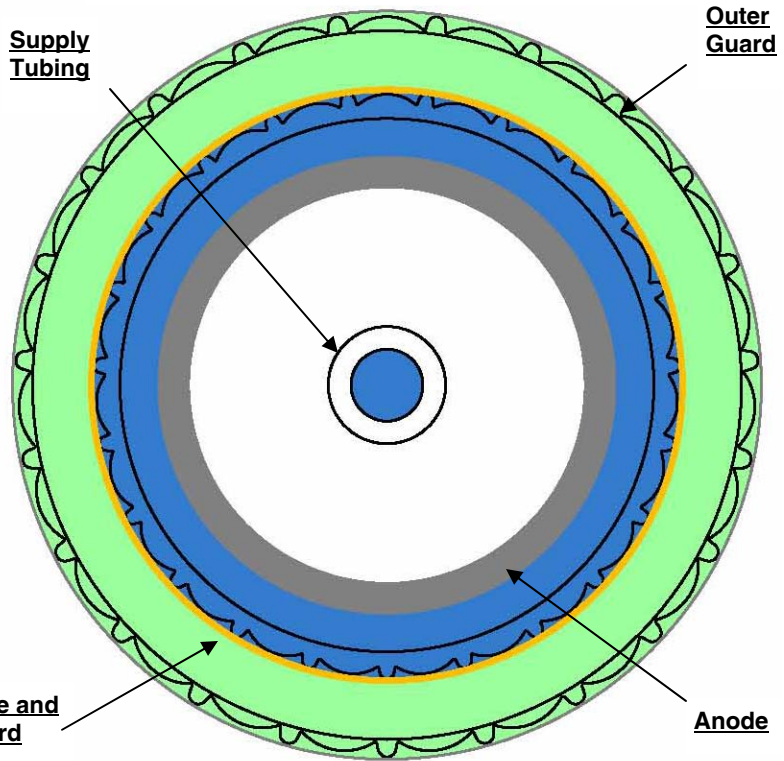

2"
TECTRON T2 Anode Cross Section

Large Diameter Cells

The UFS large diameter group of Tubular ME Cells (3" and 5") offers automotive E-coat paint system operators an up-sized TECTRAN Cell, providing the operational advantages of tubular cells while reducing the number of connections required. They are designed to retrofit easily into existing E-coat paint systems.

Note: The TECTRAN T3 3" Cell is not shown. It's cross-section fits inside the T5 cross-section shown below.

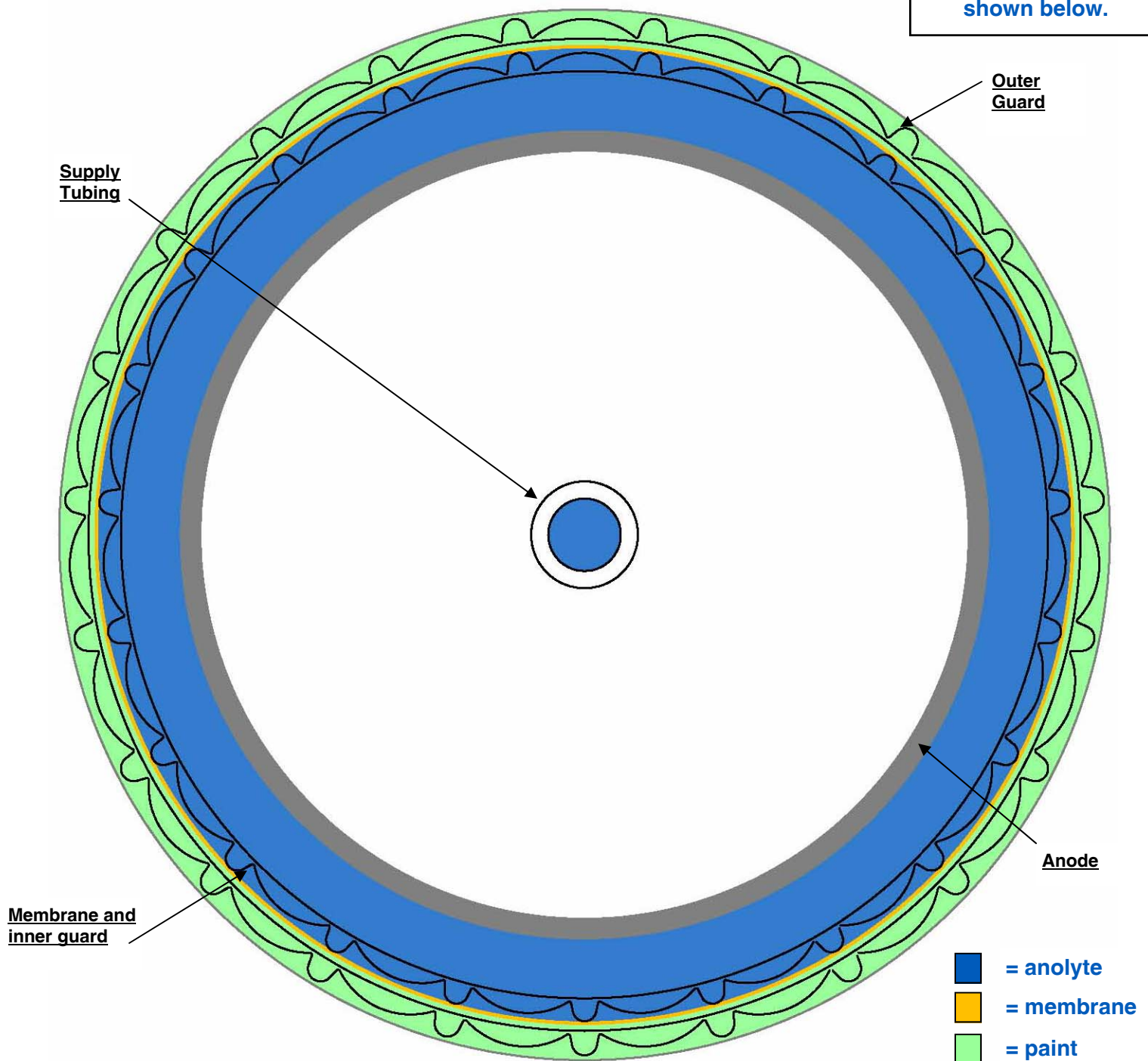

5"
TECTRAN T5 Anode Cross Section

ME Cell Configurations

The table below enumerates some of the standard and optional features of the various sizes and shapes of our ME Cells.

S = Standard **O = Optional** **N = Not Available**

ME Cell Feature/Configuration	Small Dia. TECTRON Cell		Large Dia. TECTRON Cell		One+ C Cell	One+ Box Cell
	1-1/2"	2"	3"	5"	P4	B5
Sheet Form Ion-exchange Membrane ¹	O	O	O	O	O	O
Roll Form Ion-exchange Membrane ¹	S	S	S	S	S	S
316L Sch. 40 Electrode	S ²	S ²	N	N	N	N
316L Sch. 10 Electrode	N	N	S	S	N	N
316L, 3.4 mm (0.135") thick Electrode	N	N	N	N	S	S
Precious Metal Anode ³	O	O	O	O	O	O
Membrane Guard	S	S	S	S	S	S
1.5 m (60") PVC Supply Tubing	S	S	S	S	S	S
Side ME Cell Open Top	S	S	S	S	S	S
Side ME Cell Low Profile Bulkhead ⁴	O	O	O	O	N	N
Universal Rim Mount	N	N	N	S	S	S

1. Please refer to Technical Reference 991113 on our website (www.ufsc.com) for a more detailed description.
2. S40 Seamless, S80 and S80 Seamless Electrode material is available on request.
3. While precious metal anodes are recommended for acrylic paints and high through-put E-coat paint systems, their pricing is subject to market fluctuations.
4. More information on Low Profile Cells can be found on our website. Look for Product Data Sheet 995115 or Technical Reference Bulletin 991005.

Anode Surface Area Comparison

Providing sufficient anode surface area to meet the work area basis is a critical element of a smooth-running e-coat system. The tables below provide, by size, the surface area per unit of length for our ME Cell products.

Electrode Surface area per unit of length:

<u>size</u>	<u>per meter</u>	<u>per foot</u>
1-1/2"	0.152 m ² /m	0.497 SF/ft
2"	0.190 m ² /m	0.622 SF/ft
3"	0.280 m ² /m	0.916 SF/ft
5"	0.444 m ² /m	1.456 SF/ft
One+ P4 C-Cell	0.430 m ² /m	1.407 SF/ft
One+ Box Cell	0.560 m ² /m	1.833 SF/ft

ME Cell Electrode Surface Area by Standard Effective Lengths ¹

		1-1/2"		2"		3"		5"		One+ P4		One+ Box	
Effective Length		Surface area		Surface area		Surface area		Surface area		Surface area		Surface area	
mm	inch	SM	SF	SM	SF	SM	SF	SM	SF	SM	SF	SM	SF
910	35.8	0.138	1.49	0.172	1.86	n/a	n/a	n/a	n/a	n/a	n/a	n/a	n/a
1400	55.1	0.212	2.28	0.265	2.86	0.391	4.21	0.621	6.69	n/a	n/a	n/a	n/a
1900	74.8	0.288	3.1	0.36	3.88	0.531	5.71	0.843	9.08	0.815	8.77	1.06	11.43
2300	90.6	0.349	3.75	0.436	4.69	0.642	6.91	1.021	10.99	0.986	10.62	1.29	13.84
2900	114.2	0.44	4.73	0.55	5.92	0.81	8.72	1.287	13.86	1.244	13.39	1.62	17.45

¹ Effective length is the distance from the liquid paint level to the bottom edge of the ion-exchange membrane for a Side ME Cell.

One+ C-Cells and and Box Cells

One+ C-Cells and Box Cells were developed in response to our customer's concerns with conventional c-cell and box cell designs. Our designs appeal to those inclined toward semi-circular or box cell geometry and overcome flaws found in competitive designs.

Installation Accessories

UFS has a complete range of accessories to facilitate installation of our ME Cells. In addition, UFS has design tools and installation template drawings (electrical, mechanical, and piping) to make the installation a snap.

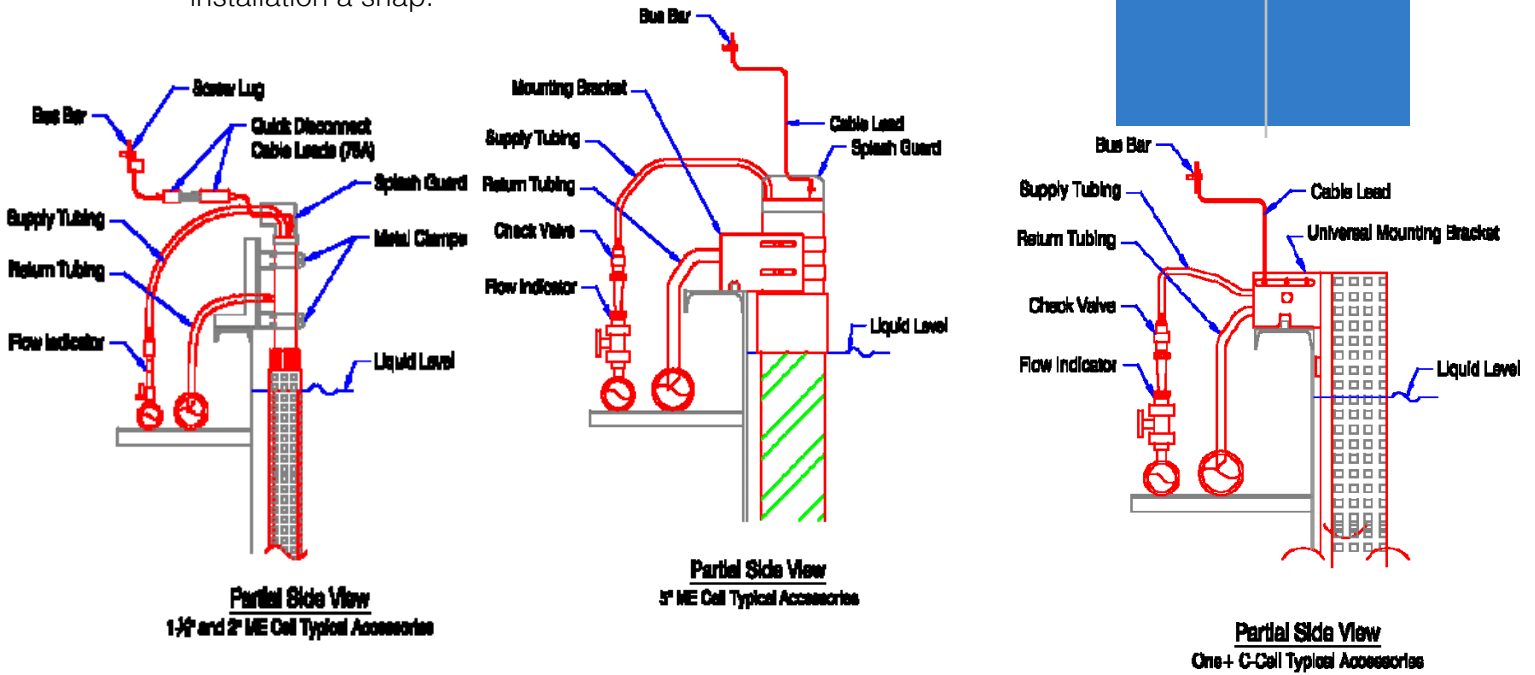

Recommended Installation Accessories List

A = Available N = Not available I = Included (in Cell price)

ME Cell Installation Accessories (<i>Order Separately</i>)	TECTRON		TECTRON		One+ C-Cell & Box
	1-1/2"	2"	3"	5"	
Universal Bracket	N	N	A	A	I
2 piece Clamps	A	A	A	A	N
1.5 m (60") PVC Return Tubing	A	A	A	A	A
Flow Indicator/Valve	A	A	A*	A*	A*
Splash Guard	A	A	A	A	I
75 Amp Cable Lead with Quick Connects	A	A	N	N	N
120 Amp Cable Lead with Quick Connects	N	N	A	A	A
Diode**	A	A	A	A	A

* Includes check valve to prevent siphoning.

** Mounts to bus bar or user provided heat sink.

Additional Products

TruIDL™ Data Logger

This affordable, miniature, submersible data logger with intuitive interface measures and records voltage on the surface of your ware as it travels through an E-coat paint tank.

After a run, the portable module connects to your computer via a mini USB cable and allows you to quickly analyze the Excel based data to:

- Monitor the condition of anode cells for optimal E-Coat tank efficiency
- Ensure enhanced quality ware through preventative maintenance
- Modify anode cell placement to optimize film builds

This low-cost diagnostic tool is a “must have” for automotive and appliance manufacturers as well as small job shops.



View of TruIDL Module

Replenishment Paint Feeder

Regular and routine monitoring of ME Cells can help avoid production problems and improve quality control. Electrical current data, when viewed over a period of time, is an excellent service tool. Performance issues and likely replacement periods for ME Cells become apparent to the user. UFS offers several options for monitoring ME Cell's electrical performance, including the New Generation ME Current Monitor, Replenishment Paint Feeder System, Auto Voltage Controller and Conductivity Controller.



Replenishment Paint Feeder Controller

Cell Circulation System

As part of an electrocoat paint system, a Cell Circulation System (CCS) monitors and maintains electrolyte (either anolyte or catholyte) flow and conductivity.

UFS Corporation's Standard CCS features a polypropylene tank, corrosion resistant magnetic drive pump, simple conductivity sensor, low liquid level sensor, strainer, and pressure gauge. We offer four distinct sizes that range from 170 liters (45 gal) to 1420 liters (375 gal).

UFS Corporation's upgraded CCS features a 304 stainless steel tank, vertical CPVC pump, 0—20k μ S/cm conductivity controller, low liquid level sensor, strainer, totalizing flow meter and pressure gauges. Four distinct sizes are available, ranging from 114 liters (30 gal) to 568 liters (150 gal).



Standard Cell Circulation System.

UFS Corporation
330 North 400 East
Valparaiso, Indiana 46383-9704 USA
+219-464-2027
+219-464-8646 (Fax)
www.ufsc.com
info@ufsc.com