

Installation Reference

Topic: Power Supply, PN 281006

Please read all the instructions listed below carefully to familiarize yourself with the project before attempting to perform any of the work or unpacking any further.

Required Materials

- Old Mounting Hardware
- Power One Drawing No. 51281 Rev L

Required Tools

- Nut Driver Set

The power supply is used to provide a low voltage signal to operate the Trigger Modules (PN 210018), which in turn operates Darlington power transistors (PN 210013).

1. Sketch out the original wiring diagram.
2. Cut old output/input wires.
3. Remove the old power supply. Keep all the old hardware.
4. Solder input wire, connecting to incoming 120 VAC power (47 to 63 Hz) to terminals 1 and 4. Polarity does not matter. If other than 120 VAC power:

100: terminals 1 and 5

220: terminals 1 and 5

230/240: terminals 1 and 4

NOTE: The power supply comes set up for 120V AC power input because jumpers are already in place across terminals 1 and 3 and also terminals 2 and 4. For other input AC voltages:

100: jumper 1 and 3, 2 and 4

220: jumper 2 and 3

230/240: terminals 2 and 3

5. Solder DC output wires to - out (Black), + out (Red), com (White). On the output side of the power supply the white wire is common, red wire is plus 15 volts DC; and

black wire is minus 15 volts DC. Refer to Figure 1 for more explicit wiring instructions.

6. Fuse requirements are: 100 to 120 volts, use 2 amp fuse; 220 to 240 volts, use 1 amp.
7. Earth ground should be within 8 m (25') of the power supply.

For more information see the original manual that came with the equipment or call UFSc at the telephone number shown above.

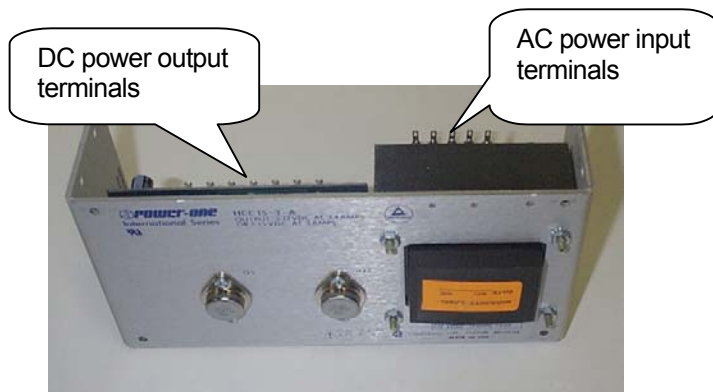

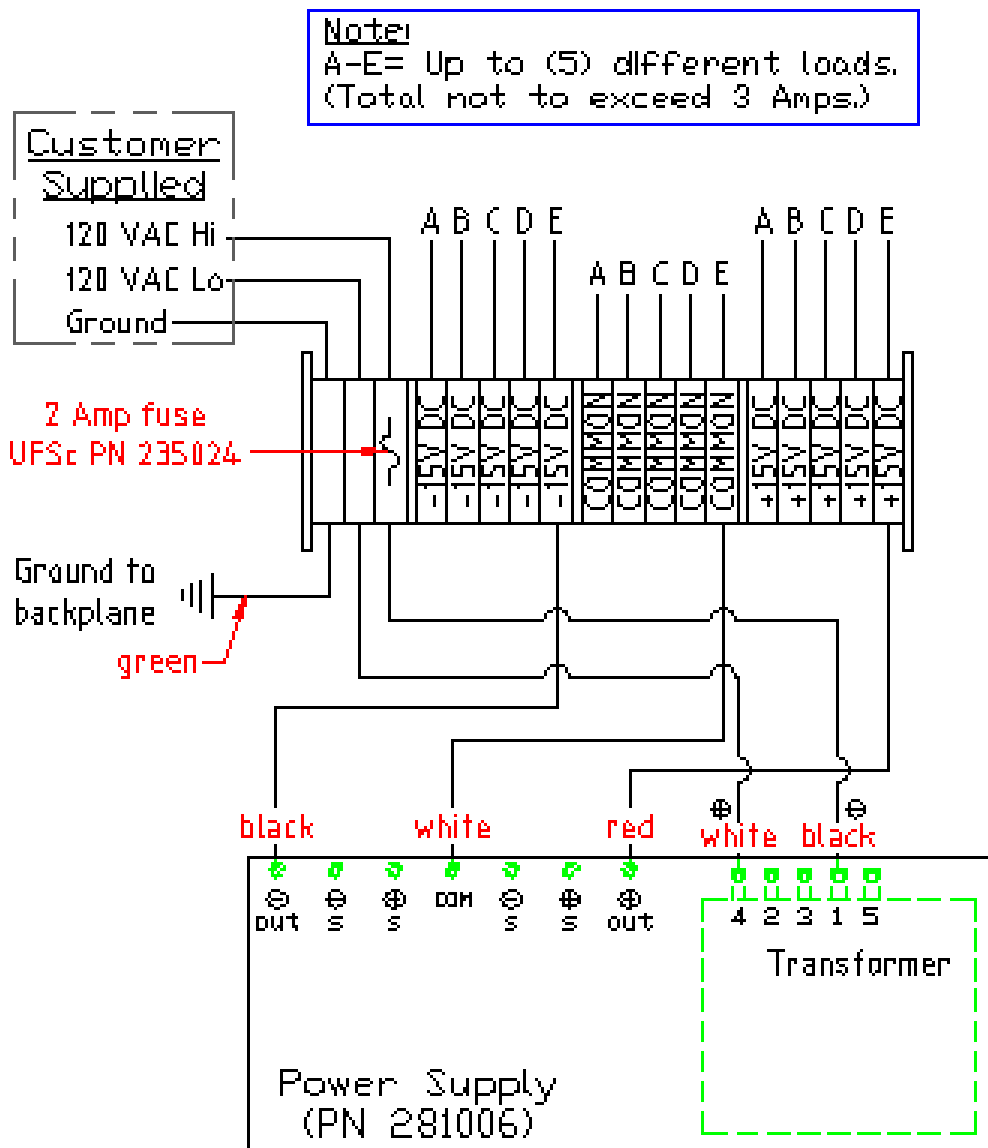

Figure 1